

Diaphragm type chemical seal

„Quick coupling“

Process connection: union nut
 or thread neck to DIN 11 851
 SMS-, IDF-, APV/RJT-Norm
 or Clamp



Description

Chemical seals are used when media can falsify the pressure measurements due to high temperatures, high viscosity (media in paste form) or their propensity to crystallise.

Chemical seals transmit the process pressure to the measuring instrument, with the diaphragm forming a hermetic seal between the medium and measuring instrument.

Hygiene regulations, such as those in the pharmaceuticals or food and beverages industries, which require cleaning of measuring point so as to leave no residue and thus ensure a sterile process sequence, can be fulfilled by the use of a chemical seal in “Quick coupling” design.

The design ensures that the process connection can be easily and rapidly released and the pressure chamber easily cleaned.

The parts of these chemical seals in contact with the medium are manufactured in stainless steel as standard. In connection with a Bourdon tube pressure gauge or a transducer, they are suitable for pressure ranges from 0...0.6 bar up to 0...40 bar.

The medium wetted parts can be manufactured in special materials for particular service conditions.

The liquid used to transmit the process pressure to the measuring instrument is foodstuff compatible.

Features

- o various process connections
- o quick coupling
- o flush diaphragm at the front
- o foodstuffs compatible filling liquids
- o special materials for extreme service requirements

Pressure ranges

0 ... 0.6 bar up to 0 ... 40 bar









Rated pressure

max. PN 40

Applications

Pharmaceutical, food and beverage industries, plant and apparatus construction, process engineering

Technical Details

Types	1030	1012	1014	1016	Options
Symbols					others on request
Process connection with union nut	DIN 11 851 DN 25; DN 32; DN 40; DN 50	SMS 1 1/2" 2"	IDF 1 1/2" 2"	APV/RJT 1 1/2" 2"	
Types	1011	1013	1015	1017	
Symbol					
process connection with thread neck	DIN 11 851 DN 25; DN 32; DN 40; DN 50	SMS 1 1/2" 2"	IDF 1 1/2" 2"	APV/RJT 1 1/2" 2"	
Types	1018				
Symbol					
Process connection with clamp	Clamp 1 1/2" 2" 2 1/2" 3"				
Instrument connection female thread DIN 16 288	G 1/4 with DN 25 G 1/2 with DN 32 with DN 50 and 1 1/2" to 3"				G 1/4, capillary welded with body and gauge adapter for gauge mounting bracket completely stainless steel, cooling element (with direct mounting and temperature >100°C)
Upper body	stainless steel 1.4571				stainless steel 1.4404; 1.4435; 1.4541; Monel;
Diaphragm	stainless steel 1.4571, welded with upper body				stainless steel 1.4404; 1.4435; 1.4541; Hastelloy B2, C4, C276; Monel 400; Nickel
Sealing ring	NBR (Perbunan) only model 3010 to DIN 11 851				PTFE only model 3010 to DIN 11 851
Filling liquid	Glycerine/water, FFL-Nr. 6				others available in consideration of process conditions
Working temperature	Tmin. -10°C Tmax. 120°C				Tmin. -10°C Tmax. 250°C

Important notes on the selection of chemical seals

The process pressure to be measured is applied to the measuring instrument by the chemical seal with the aid of a liquid. The chemical seal and measuring instrument can be connected together by capillary lines (length up to max. 15 m) for system related reasons and in order to prevent the exposure of measuring instruments to impermissibly high temperatures. The temperature drop between the instrumentation and control unit and the chemical seal can be several 100°C. Measuring errors resulting from temperature are therefore possible and may be of a magnitude several times the accuracy of the measuring instrument. The particular operating conditions can be taken into account in the manufacture of I & C device-chemical seal combinations.

Matching of the chemical seal and pressure measuring instrument therefore requires expertise, and we shall be pleased to assist you. We recommend you to request our special questionnaire on service conditions and order data.

Dimensions (mm)

with union nut
Types 1010, 1012, 1014, 1016

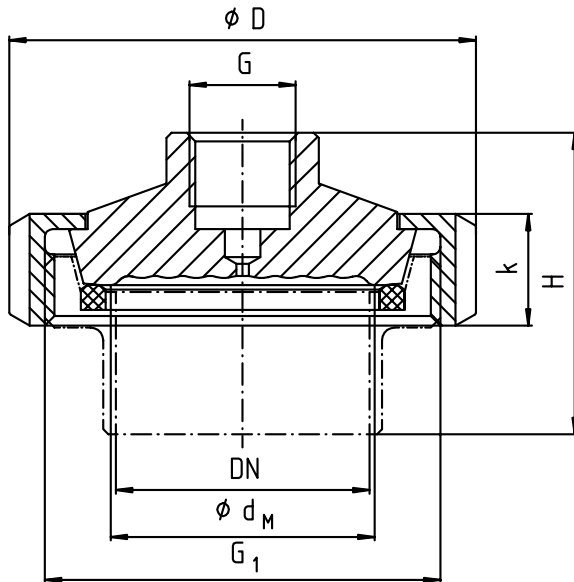

with thread neck
Types 1011, 1013, 1015, 1017

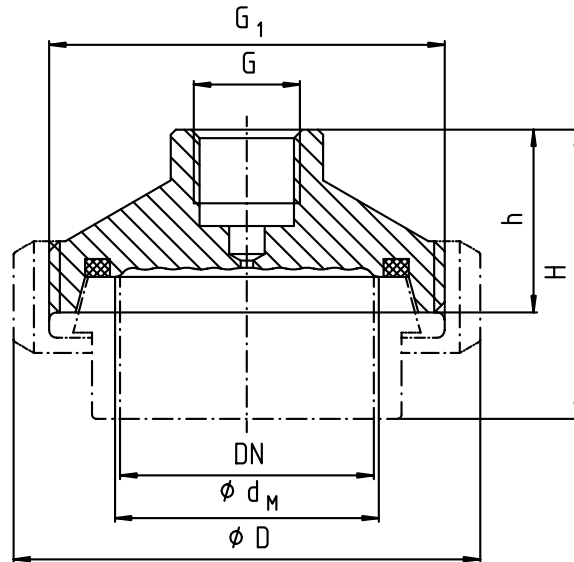

Union - nut	DN ¹⁾	PN	Dimensions (mm)							weight (kg)
			d_M	D	H_{ca}	h_{ca}	k	G_1	G_2	
DIN 11 851 BR1010	25	40	25	63	60	--	21	G 1/4	Rd 52 x 1/6	0,40
	32	40	32	70	69	--	21	G 1/2	Rd 58 x 1/6	0,50
	40	40	40	78	55	--	21	G 1/2	Rd 65 x 1/6	0,75
	50	25	52	92	59	--	22	G 1/2	Rd 78 x 1/6	0,80
SMS-Norm BR 1013	1 1/2"	40	40	74	51	--	25	G 1/2	Rd 60 x 1/6	0,75
	2"	40	52	84	51	--	26	G 1/2	Rd 70 x 1/6	0,90
IDF-Norm BR 1014	1 1/2"	40	32	64	53	--	30	G 1/2	1 1/2" IDF	0,70
	2"	40	52	79	53	--	30	G 1/2	2" IDF	0,85
APV/RJT-Norm BR 1016	1 1/2"	40	32	72	60	--	21	G 1/2	2 5/16 x 8"	0,77
	2"	40	40	86	65	--	22	G 1/2	2 7/8 x 6"	0,86

Effective diaphragm = d_M

Thread neck	DN ¹⁾	PN	Dimensions (mm)							weight (kg)
			d_M	D	H_{ca}	h_{ca}	k	G_1	G_2	
DIN 11 851 BR1011	25	40	25	63	60	44	--	G 1/4	Rd 52 x 1/6	0,50
	32	40	32	70	55	36	--	G 1/2	Rd 58 x 1/6	0,60
	40	40	40	78	55	36	--	G 1/2	Rd 65 x 1/6	0,85
	50	25	52	92	57	36	--	G 1/2	Rd 78 x 1/6	0,90
SMS-Norm BR 1013	1 1/2"	40	40	74	61	38	--	G 1/2	Rd 60 x 1/6	0,90
	2"	40	52	84	61	38	--	G 1/2	Rd 70 x 1/6	1,00
IDF-Norm BR 1015	1 1/2"	40	32	64	63	40	--	G 1/2	1 1/2" IDF	0,73
	2"	40	52	79	63	40	--	G 1/2	2" IDF	0,88
APV/RJT-Norm BR 1017	1 1/2"	40	32	72	60	35	--	G 1/2	2 5/16 x 8"	0,85
	2"	40	40	86	65	35	--	G 1/2	2 7/8 x 6"	1,10

Effective diaphragm = d_M

¹⁾ The dash dotted screwed connections in the dimensional drawings are available on request.

Dimensions (mm)

Clamp-connection Types 1018

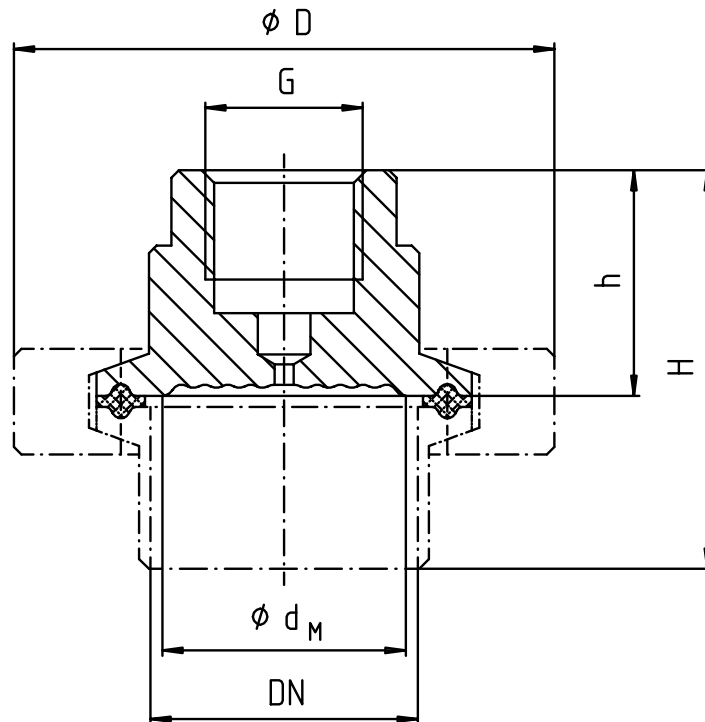

Clamp-connection	DN ¹⁾	PN	dimensions (mm)					weight (kg)
			d_M	D_{ca}	H_{ca}	h_{ca}	G	
BR 1018	1 1/2"	40	32	60	58	35	G 1/2	0,60
	2"	40	40	75	58	35	G 1/2	0,75
	2 1/2"	25	52	82	65	35	G 1/2	0,95
	3"	25	72	104	65	35	G 1/2	1,30

Effective diaphragm = d_M

1) The dash dotted screwed connections in the dimensional drawings are available on request.

Ordering details:

Type / process connection (size/norm) / material (wetted parts) / instrument connection / filling / installation at pressure gauge / process conditions as per questionnaire

Modifications reserved!